

**WHITE
LIGHTNING™**

X-Series

The White Lightning™ X-Series Operation Manual

The White Lightning™ X-Series Flash Units are manufactured and directly sold by Paul C. Buff, Inc.™ In Nashville, Tennessee. The X-Series™ includes models X800, X1600, and X3200. This manual may also be used for operation of the retired X2400 model.

The logo for Paul C. Buff, Inc. is written in a bold, black, cursive script. The word "Buff" is the primary focus, with a registered trademark symbol (®) located at the bottom right of the letter "f".

Paul C. Buff, Inc.™ • 2725 Bransford Ave. Nashville, TN 37204
toll free **1-800-443-5542** • local **615-383-3982** • **paulcbuff.com**

*Thank you for purchasing a White Lightning™ X-Series Flash Unit!
Please contact our customer service team if you need assistance.*



Safety Precautions

For your safety, please note these warnings:

WARNING! To avoid potentially lethal conditions, connect this unit only to a **3-wire grounded outlet**. Do not operate with 2-wire extension cords or use adapters to connect to ungrounded outlets.

WARNING! This unit contains **high voltages** and internal components, which can store dangerous voltages even when the unit is unplugged.

WARNING! The unit contains **NO USER SERVICABLE PARTS** and should not be disassembled except by a qualified technician. The only parts you may replace yourself are the flashtube and the modeling lamp, though caution must be taken here and the unit must be powered down while these items are replaced.

WARNING! Before attempting to operate your flash unit, securely mount the unit to a **light stand**.

WARNING! Always power down your unit and unplug it from the AC power source before removing, adding or adjusting any accessories.

WARNING! Do not allow unattended children around studio flash equipment as potentially dangerous conditions may result, including burns and electrical shock hazards. **Please be safe with your equipment!**

POWER REQUIREMENTS:

As the X-Series units require an AC power source, each unit comes with a 15-foot power cord. This cord connects to the flash unit on the back control panel with a standard IEC connector and then must be connected to a **120 VAC, 50-60 Hz** power outlet. When shooting in an environment where a suitable AC power source is not available, we recommend the exclusive use of one of our Vagabond™ Portable Power Systems. The Vagabond™ Systems are designed specifically for Paul C. Buff, Inc.™ flash units and power packs, offering a convenient, lightweight, self-contained portable power source at a very low cost (*please call us or visit our website for specific product details*).

PRODUCT DESCRIPTION:

The X-Series flash units are extremely precise, high power electronic photographic flash units. They are designed for professional studio use, as well as demanding location work due to their compact, yet highly durable construction and extruded housing. The flashpower and modeling lamp intensity may be adjusted over a stepless 5 f-stop power range, independently adjusted on separate rear panel faders. The X1600 and X3200 may additionally be switched between HIGH and LOW power modes to add another 2 f-stops and to reduce the recycle and flash duration to 1/4 of the normal power.

The unit delivers energy stored in its internal capacitor bank to a critically matched, circular hard-glass **flashtube** designed for 5600K daylight spectrum with low UV emission. This yields minimal **flash duration** while maintaining energy conversion efficacy within 1/4 of an f-stop of the maximum attainable from Xenon light sources of this type.

For wireless firing capabilities, each X-Series unit contains a sensitive **built-in slave tripper**, which is disabled when a sync cord or blank “dummy” plug is inserted into the sync jack.

Each unit arrives with a 250 Watt quartz **modeling lamp**. This long-life bulb is encased in a large, frosted glass envelope to eliminate hot spots and pattern errors that are common to small, clear-envelope household bulbs. The unit offers highly accurate modeling, boasting “what-you-see-is-what-you-get” modeling. This is a result of careful engineering of the flash and modeling components with respect to polar patterns, specular content, and accurate tracking of light ratios from both sources. With respect to tracking accuracy, the units employ full voltage regulation of the flash circuits as well as the modeling lamp circuits, allowing the system to maintain consistent flash and model ratios under real-world powerline conditions. The modeling lamp may be set on FULL power, adjusted with the rear panel fader over the same available range as the flashpower, or turned completely OFF. The lamp may be additionally set to indicate recycle, going out when the unit is fired, then coming back on to indicate when recycle is complete.

A full range of **accessories** are compatible with the X-Series units, as a quick-release mechanism attaches the entire line of standard Paul C. Buff, Inc.™ reflectors and modifying accessories, while dual holders allow the simultaneous use of umbrellas and counter weight shafts.

WHAT ARRIVES WITH EACH X-SERIES FLASH UNIT:

A Standard, User-Replaceable 250 Watt Modeling Lamp (part# Q250W)

- *250 Watt, 4600 Lumens Quartz Edison-base light bulb*
- *3000 hour+ typical life expectancy*

A14mm, 5600°K Daylight-Balanced Flashtube (part# AWFT14MMUV)

- *user-replaceable flashtube*
- *250,000+ flashes typical life expectancy*

A 7-inch (80° Beam Spread) Silver Field Reflector (part# 7AB/R)

- *recessed outer lip for snapping in our honeycomb grids*
- *pre-cut umbrella hole (fits standard poles up to 3/8-inch in diameter)*

A Standard 15-foot Power Cord (part# UPC15)

A Standard 15-foot Sync Cord - 1/4-inch Stereo Plug to PC (part# SC)

A Black Polycarbonate Shipping Cover (part# 1060032)



THE X-SERIES CONTROL PANEL:

The Control Panel on the X-Series flash unit offers you clear control of the unit's features, conveniently labeled and collectively located for simple and quick manipulation.

Note: The Blue "RANGE" Switch that allows the unit to switch from High Power to Low Power mode is only available on the X1600 and X3200 models (NOT on X800 models).



Slider Control of Flashpower

The flashpower is independently adjusted with the top slide fader (marked with lightning bolts on either side) over a complete 5 f-stop range, from Full down to 1/32nd of the total power. The slider adjusts the flashpower steplessly, in whole f-stop increments and everywhere in between.



Slider Control of Modeling

The modeling lamp output is independently adjusted with the lower slide fader (below the flashpower slider, marked with light bulbs on either side) over the same full 5 f-stop range.



Modeling Lamp Control (MODEL)

The white "MODEL" button is the ON / OFF switch for the modeling lamp. When depressed, the modeling lamp will be turned ON; when released, the modeling lamp will be turned OFF. The lamp must be turned on before the READY feature may be used.



Modeling Lamp Recycle Indicator (MODEL = READY)

The black "READY" button is the ON / OFF switch for the modeling lamp recycle status indicator feature. When depressed, the lamp will visually indicate the unit's recycle status by dimming after each flash (as the unit recycles). When the modeling lamp comes back on, this indicates that the unit has recycled and is ready to flash again at the indicated settings. With the switch released, the lamp will remain on at the output level indicated through the shoot.



Recycle Indicator Ready Light

The "READY" light shines green to indicate that the unit is recycled and ready to flash at the indicated settings.



Test Flash

The red “TEST” button allows you to test flash your unit.



Range Switch **on the X1600, X2400 and X3200 units only*

The blue “RANGE” button switches the unit from High Power (Full) to Low Power (1/4) mode. When in High Power mode, the unit is using all of its capacitors and the flashpower slider will adjust the output over a stepless 5 f-stop range from Full down to 1/32 power. When in Low Power mode, the unit is using only 1/4 of its capacitors and the flashpower slider will adjust the output over a stepless 5 f-stop range from 1/4 down to 1/128 power. As the modes overlap, there is a total of 7 f-stops available. When in Low Power mode, the flash duration and recycle time is decreased by a factor of 4, and the modeling lamp will be set to dimmed to 1/4 of its power. *The unit will test flash itself whenever you switch the range.*



Remote Control Jack

This standard RJ-11 connector jack accepts the four-conductor telephone cords provided with each Paul C. Buff, Inc™ remote control for remote operation of functions.



Slave Tripper (SLAVE cell)

The unit contains a sensitive built-in slaver tripper, which fires the unit whenever it “sees” the light from another flash unit or from an infrared signal. The slave tripper can be disengaged by plugging a sync cord or a blank “dummy” jack into the sync jack.



Sync Jack

The sync jack allows you to connect the unit to your camera with the provided sync cord (PC-connection). When a sync cord or blank “dummy plug” is connected, the slave tripper is disengaged and the unit will only fire from the connected camera (or remote control, if connected). The X-Series trigger / sync voltage is under 6 volts.



Dump Light

The “DUMP” light indicates the unit’s charge / overcharge status. This light shines red when the unit is charged to a higher flashpower than what is selected (when the flashpower is changed from a higher to a lower setting). To avoid overexposing the next frame, wait for the “DUMP” light to go out (the unit will automatically dump the excess charge). Depending on the power adjustment made, the automatic dump may take up to one full minute, but you can instantly dump this charge by pressing the “TEST” button to flash the unit.



Circuit Breaker Reset Button

The "RESET" button allows you to reset the circuit breaker if it is tripped from excessive, rapid use. Pressing this button in will reset the circuit breaker.



ON / OFF AC Power Switch

The Power Switch, located above the Power Cord Jack, is the main ON/OFF switch for the flash unit.



Power Cord Outlet

Each X-Series unit is supplied with our 15-foot AC Power Cord to connect the unit to a 120 Vac, 50-60 Hz power source. The power cord is plugged into this outlet (with a standard IEC Connector), then into a grounded power outlet. The flash units will not function properly if the ground is defeated. For safety, using a surge protector is recommended when multiple flash units are plugged into a single outlet.

FRONT VIEW DIAGRAM

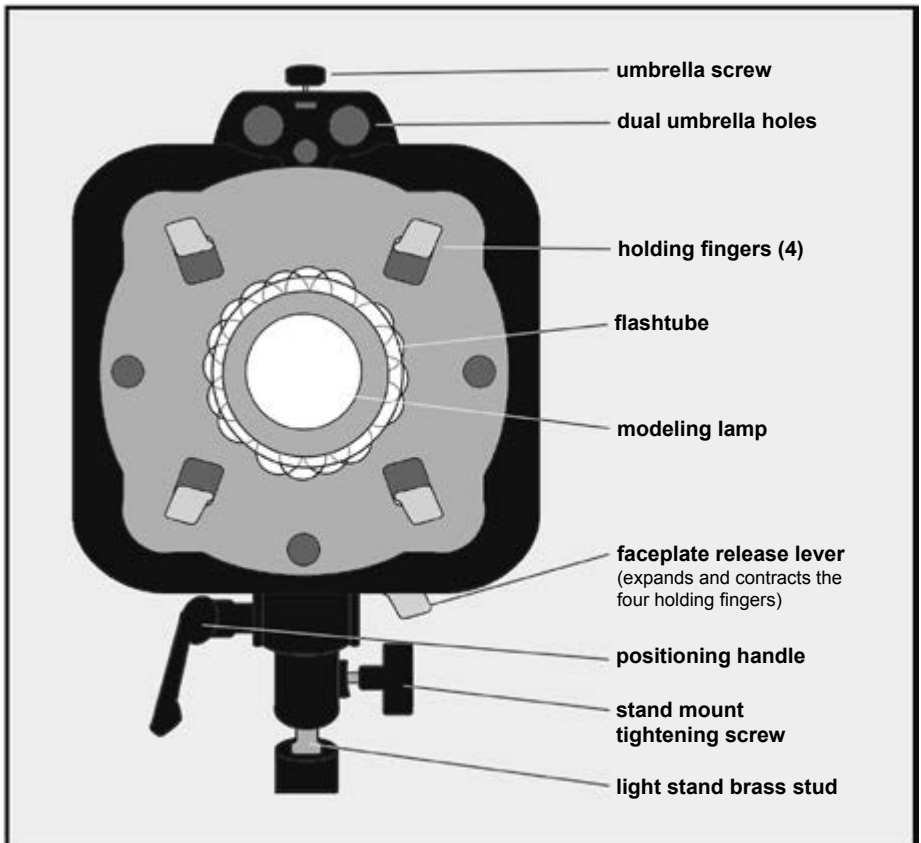

X-SERIES FEATURES

Built-in Cooling Fan

While the units incorporate axial-flow thermodynamics to reduce heat build-up, each unit also has a built-in, forced air cooling fan to prevent overheating. The thermostatically-controlled fan automatically comes on when temperatures rise from extended use (at 104° F).

Warning Alarms

Each unit contains audible warning alarms to indicate overheat and misfire. If the unit's temperatures reach higher levels where the internal components may be threatened, the unit will produce a periodic tone. Continued use will increase the urgency of this tone. Should the **overheat alarm** sound, it is best to power down your unit and allow it to cool. If the flash unit is triggered but fails to fire properly, the **misfire alarm** will sound for one second. If this alarm sounds, first check your flashtube to ensure that it has not broken or come loose. *If either alarm fires and you are unable to correct the problem, please contact our Customer Service Department at 1-800-443-5542.*

The Housing

The units are housed in aircraft-grade aluminum extrusions with molded polycarbonate rear bezels. Our swivel stand mount is attached to the housing (with a tightening knob to attach your unit securely to a light stand) and an adjustment arm to change the position and direction of the unit.

SETUP INSTRUCTIONS

1. Remove the shipping cover.

Your flash unit arrives with a black polycarbonate shipping cover in place. **You must remove this cover prior to operation.** The cover is held in place with four fingers on the faceplate of the unit, which are used to hold accessories as well (such as reflectors and softbox speedrings). To remove the cover, slide the silver **faceplate release lever** to the left. This will cause holding fingers on the faceplate to contract, allowing you to pull the shipping cover straight off of the faceplate. Releasing the lever will allow the holding fingers to expand back into the holding position.

2. Securely mount your flash unit to an appropriate light stand.

The black swivel mounting bracket allows you to affix your unit to any of our light stands. Once you have expanded the footprint of the stand to its stable position, set the unit on top of the stand and allow the brass stud to slide inside the opening. Use the black knob on the mounting bracket to tighten the screw and secure the position. Use the black positioning handle on the bracket to adjust the direction and angle of the flash unit. Once your unit is securely mounted and positioned, you may then adjust the height of the stand. *See the images on the following page to learn more.*



Note: The X-Series stand mount fits light stands with 5/8-inch or smaller studs.

3. Attach your accessories.

Reflectors: To attach any of our reflectors to the faceplate of your flash unit, you will use the faceplate lever to expand and contract the holding fingers in the same manner used to remove your shipping cover. When you slide the lever to the left, the holding fingers will contract, allowing you to place your reflector around the fingers. When the lever is released, the fingers will expand to hold the reflector securely in place. For proper fitting, ensure that all four fingers are holding the inside of the reflector.

Softboxes and Octaboxes: The speeding of your assembled softbox will fit on the faceplate in place of the reflector, attached and removed as the reflectors are, with the holding fingers.

Umbrellas: You may use an umbrella with the standard 7-inch reflector or bare-bulb. Line up the hole in the reflector with either of the dual umbrella holes in the unit's housing. The umbrella pole fits through either hole and is then tightened in place with the black screw.

Honeycomb Grids: To use our 7-inch grids you will need either the standard 7-inch reflector (included with the flash unit) or the UMF LiteMod Unit Mainframe. With either reflector attached, you can snap one grid directly into the recessed outer lip.

Gels / Filters: Our gels / filters may be used with the UMF LiteMod Unit Mainframe (sliding into the frame using the GELH Gel Holders) or with the UBR Background Reflector or standard 7-inch reflector.

Please see the individual accessories for a complete description of use and attachment, or call us should you need assistance.

4. Connect your power cord and turn the unit ON.

The provided 15-foot power cord connects to the flash unit on the back control panel, then plugs in to a 120VAC, 50-60Hz power outlet. With the power cord connected, turn your unit on. The green READY light indicates that your unit is powered and ready to fire.

5. Connect your sync cord to your camera.

The 1/4-inch male stereo plug on one end of the provided sync cord plugs in to the sync jack on the back panel of the unit; the other end of the cord will connect to your camera's PC outlet. When the cord is plugged into the sync jack, the flash unit will fire. This flash will indicate that the sync cord is detected, and that the unit will take its cues to fire from your connected camera.

***If your specific camera does not have a PC outlet, we offer a hot shoe adapter that fits in the standard ISO hot shoe of most cameras to enable PC-connection (part# HSA, sold separately on our website).*

6. Adjust your positioning and flashpower settings.

The output settings that you choose will vary based on your subject, your environment and your desired effects. The positioning will vary as well, depending on the coverage, distance and intensity required. The modeling lamps will help you to determine positioning as they will show you exactly where your light will hit, matching the specularity of the source with any modifying accessories. With your flash unit powered ON and connected to your camera, you are ready to take a meter reading of the light, adjust your camera settings, and begin shooting.

METERING

When using flash units and various light modifying techniques, the best way to ensure a proper exposure is to use a high quality, dedicated flash meter. There are several manufacturers who offer excellent meters, allowing you to enter the specific settings that you've chosen for a shot, and read the amount of light present. You can connect the provided sync cord directly to a hand-held meter, and select the "cord" option for the meter's fire signaling. Once you have entered the appropriate film speed (ISO) and shutter speed into the meter, you are ready to take a reading. The meter's "test" or "fire" button will fire the unit(s) in your setup, and indicate the appropriate settings so that you may set your camera controls accordingly. A reading from the camera position or from the subject position may be used to determine an overall average scene reading. Depending on the subject, you may additionally want to take spot meter readings. With these readings, you can set your camera's controls appropriately for the amount of light present, considering the aperture and shutter speed needed for the specific effect desired. Once you have taken your reading, made necessary adjustments, and set your camera's controls, you can remove the sync cord from the meter and return it to your camera. You are now ready to shoot.

Note: When metering for a correct exposure, you **cannot rely on your in-camera meter**, as it cannot detect the light that will be produced by the flash unit(s) when fired. Additionally, your camera may employ a Through-The-Lens Meter (TTL) which can inadvertently trip your unit's built-in slave tripper, causing the unit to prematurely flash.

AUTOMATIC VS. MANUAL CAMERA MODES

The automatic mode is a setting on your camera that allows the camera to use its internal meter to automatically adjust the aperture and shutter speed for a shot based on the prescribed ISO setting, and the available light. When using studio flash units, you cannot leave your camera in automatic mode, as its internal meter will not be able to detect the light that will be emitted by your flash units, and will thus be set to an inaccurate shutter speed and aperture opening, causing your picture to be overexposed.

Manual exposure is a camera mode which is non-automatic and requires the photographer to set their own ISO, aperture, and f-stop for each shot. This mode does not rely on the camera's internal metering system, but rather requires you to take a reading with a separate flash meter to determine correct settings. When using external flash units, your camera should be adjusted manually.

RECOMMENDED LONG TERM USE

For the X-Series X800 and X1600, up to 400 full power shots per hour may be used. This will increase at lower power settings, and excess use will be identified by the unit's overheat alarm. With the X3200, up to 240 full power shots per hour may be used, also increasing with lower power settings. Always power down then unplug your unit when not in use.

FREQUENTLY ASKED QUESTIONS

Q: What will trigger the built-in slave tripper?

A: Our built-in slave tripper is sensitive to both **visible and infrared flashes of light** and will be triggered by conventional flash. It will in fact, be triggered by any light flash that it "sees." One flash unit in your setup will reliably fire all of the other flashes, allowing wireless firing. The slave cell will be tripped by an on-camera conventional flash and an infrared slave as well. The slave may be inadvertently tripped by flashes from other photographers in the area and / or other infrared signals or pre-flashes as well.

Q: Can the built-in slave tripper be turned off?

A: Yes. The internal slave sensor is automatically disabled when a sync cord or blank dummy plug is inserted in the sync jack. With the sync cord inserted, the unit will only take its cue to fire from your camera. To disengage the slave tripper without connecting it to your camera, you can simply insert a blank "dummy plug" into the sync jack. *(A dummy plug is simply a 1/4-inch blank stereo plug and you can order these from us should you need any.)*

Q: Should I be concerned about the sync voltage?

A: Digital camera users are often concerned about the sync / trigger voltage as units with high voltages can be unsafe for the camera. The X-Series Flash Units, however, use a **low sync voltage** (under 6 volts) which is safe for use with a hot shoe adaptor or PC sync connector. Some flash units, especially cheap or old units, use sync voltages as high as 50-60 volts which can damage some cameras. Most digital cameras can accept up to 6 volts synced. You can check your camera's manual to confirm its maximum allowable sync voltage.

Q: My X-Series unit does not fire. All I hear is a 'clicking' sound. The ready light comes on and the modeling lamp works, but there is no flash. What does this mean?

A: If the ready light comes on, and you hear a faint click when you push the test button, the most likely problem is an exhausted flashtube. Flashtubes become exhausted based on use, and a new flashtube should fix the problem.

Q: I'm having problems with my supplied sync cord fitting into the light and the PC connection on my camera. Did I get the wrong cord?

A: The sync cord supplied with your flash unit is a 15-foot cord, with a 1/4 inch stereo plug on one end, and a PC connector on the other end. To insure a proper connection, you must push both the PC connection and stereo plug in fully, until they cannot be pushed in any further. Simply pushing the stereo plug in one more "click" solves many problems of this nature. However, given manufacturing tolerances, it is only natural to get an occasional "minus" sync cord mating up with a "plus" camera PC connector, and vice versa. A PC connector set requires a tight fit to prevent misfires, and there are slight size differences occasionally noted between a camera manufacturer's PC outlet, and cord manufacturer's PC cord. While this is rare, if you feel that your cord simply won't match, please contact us.

***If your specific camera does not have a PC outlet, we offer a hot shoe adaptor that fits in the standard ISO hot shoe of most cameras to enable PC-connection (part# HSA, sold separately on our website).*

*If you have other questions, please contact us! You can call us on our toll free line at **1-800-443-5542** or on our local line at **615-383-3982**. We're here Monday through Friday, from 9:00am until 5:00pm, CST. You can email us as well at **info@paulcbuff.com**.*

ABSOLUTE SATISFACTION GUARANTEE

Paul C. Buff, Inc.™ offers a **60-Day Absolute Satisfaction Guarantee**. If, for any reason, you are not satisfied with the equipment that you have purchased from Paul C. Buff, Inc.™, you may return your equipment within 60 days for a complete refund minus the cost of shipping.

WARRANTY

Paul C. Buff, Inc.™ offers a **5-Year Factory Warranty** on all White Lightning™ X-Series (X800, X1600 and X3200) flash units. The obligation of Paul C. Buff, Inc.™ is limited to the repair or replacement of products that have become defective under normal use, as outlined in the manual. The warranty does not apply to the flashtubes or modeling lamps as these become exhausted based on normal use (except in the unusual case of an unexpected manufacturer's defect). Should you experience any difficulties, please contact us so that we can assess your predicament and let you know if we need to bring in your unit for repair.

*This product was **Made in the USA** by Paul C. Buff, Inc.™*

2725 Bransford Avenue Nashville, Tennessee 37204
Toll Free Customer Service Line: 1-800-443-5542
Local: 615-383-3982 Fax: 615-383-0676
e-mail: info@paulcuff.com

www.PAULCUFF.com